

One-Line Diagram - OLV1=>RED MVT3 (Arc Flash)

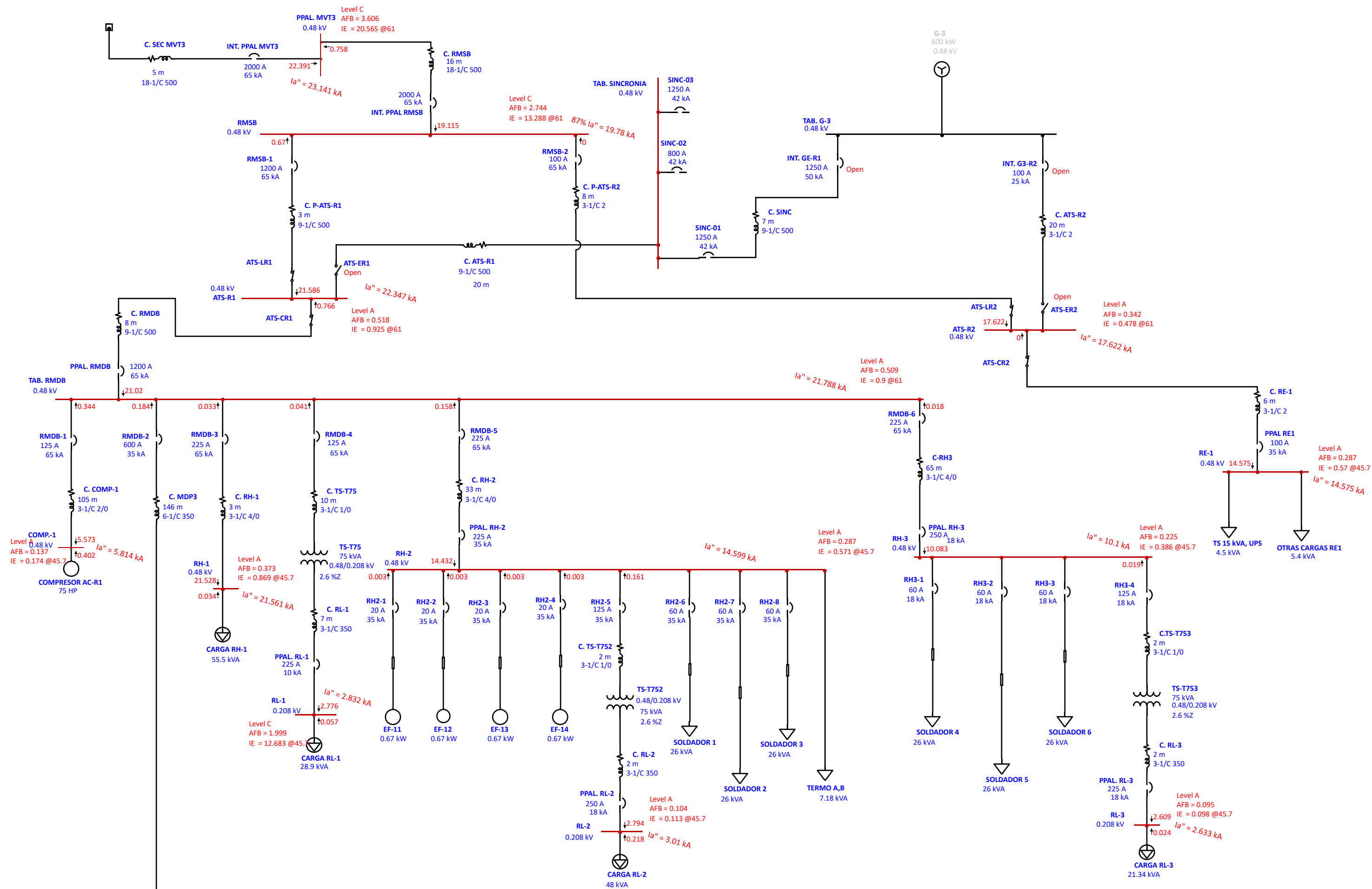

One-Line Diagram - OLV1=>RED MVT3 (Arc Flash)

